

Cutting Pro™ for Product Packaging Mockups

**NEW**

# FC4210-60

**Built-in specialty functions for creating sample presentation boxes from F/G grade microflute board and paperboard**

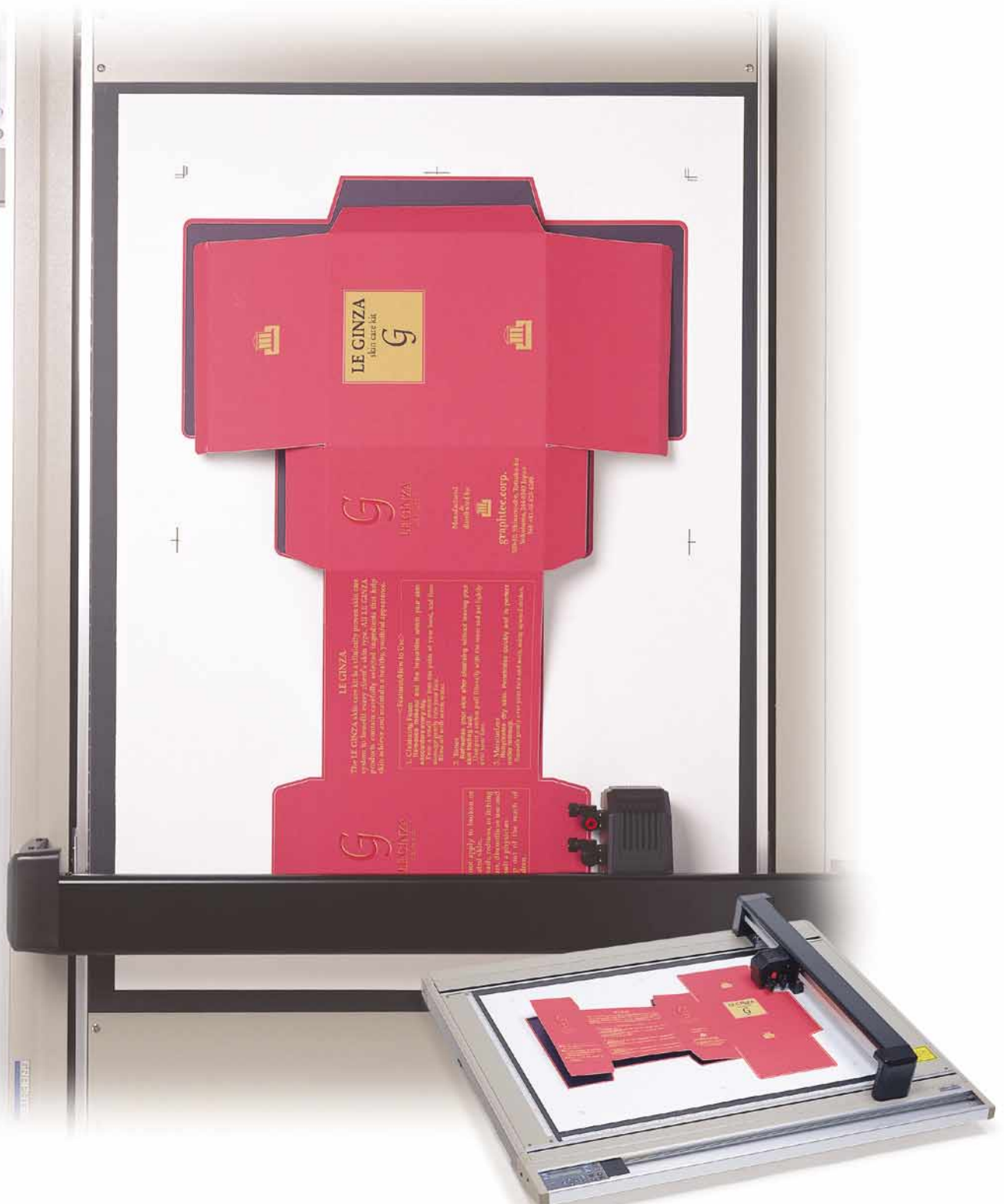

# Fast, easy production of product packaging mockups. Easy-to-use functions for cutting and scoring of microflute board (F/G grades) and paperboard.

The FC4210-60 features built-in specialty functions for accurate, easy cutting of microflute board and cardboard to create prototype boxes for client presentations.

The ability to read registration marks generated by Adobe® Illustrator®, substrate-specific creasing/scoring on the reverse side to create fold lines, and specifiable cutting and creasing/scoring forces to suit the characteristics of the substrate are all functions that meet industry needs for high-performance cutting.

Improve your productivity with Graphtec's newest addition to the Cutting Pro™ family.

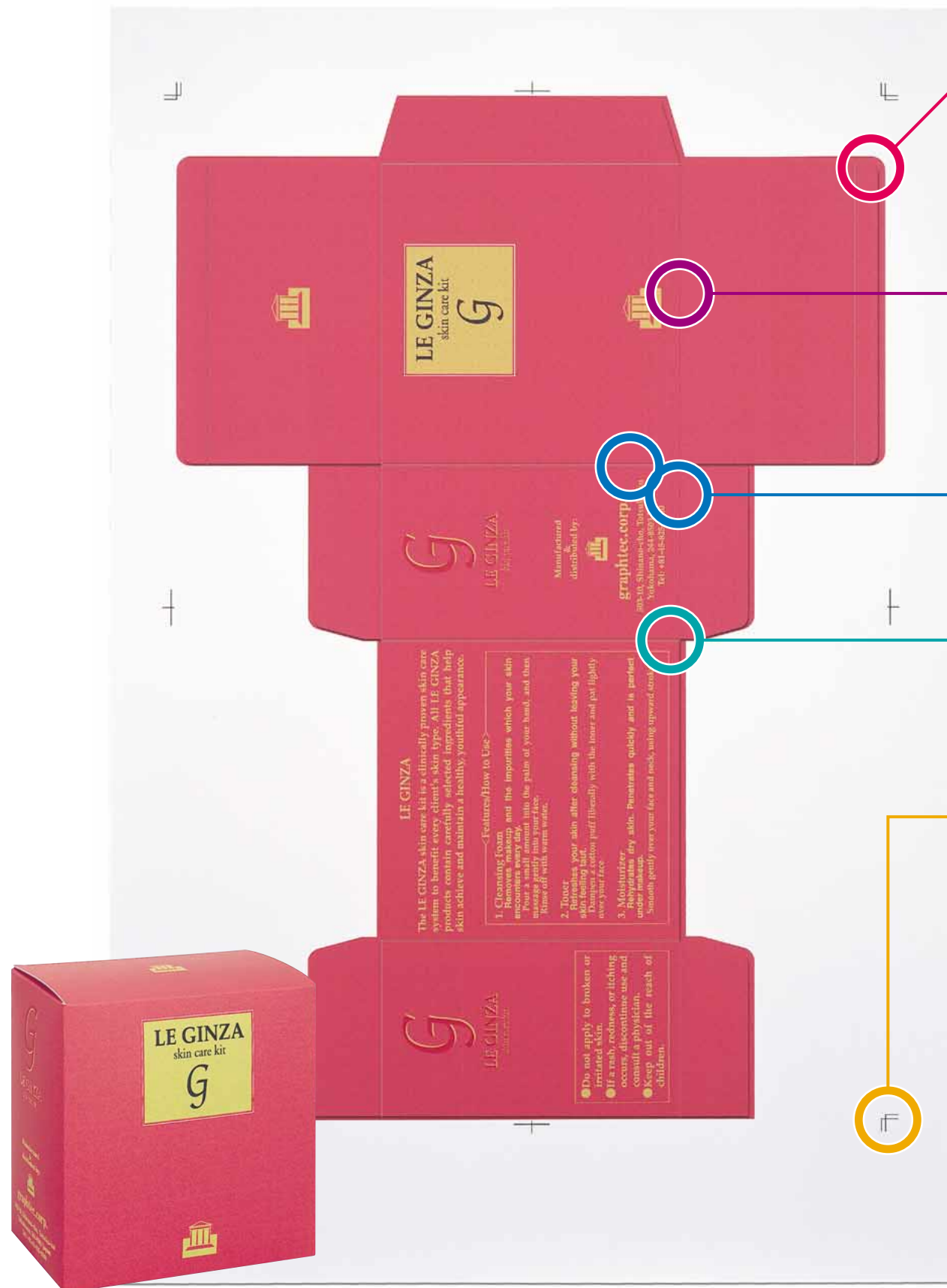

## Tangential Emulation for High-performance Cutting

The FC4210-60 uses a cutter plunger with a supersteel blade to cut smoothly through a wide range of substrates. Graphtec's proprietary tangential emulation provides consistently accurate and clean cutting even on microflute board (F/G grades) and paperboard, ensuring sharp edges and corners.

*Note: There may be some substrates that the FC4210-60 cannot cut effectively. Please contact your Graphtec vendor or distributor in order to arrange for free test cutting of the substrates you plan to use before you purchase the machine.*



## Substrate-specific Creasing/Scoring Functions

Graphtec has developed a proprietary, user-specifiable substrate creasing/scoring function so that even the most rigid substrates can be folded cleanly. Select single-line, double-line, or triple-line scoring. For double-line or triple-line scoring, you can also specify the spacing between the lines. Use double-line or triple-line scoring to lessen the chances of the fold line tearing or pulling apart when the box is folded.

### How to determine the number of scoring lines

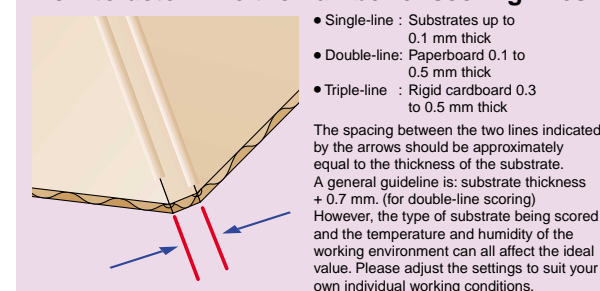

## Independent X/Y Direction Force Settings

The creasing/scoring force and the cutting force can both be specified independently for the X and Y directions to suit the special characteristics of microflute board (F/G grades). This function prevents damage to the surface that can be caused by too high a force being applied.

## 2-Tool Mounting for Easy Switching

Two tools can be mounted at the same time for easy switching. If you mount the cutter plunger and the creasing/scoring tool at the same time, you can perform both cutting and scoring operations without having to exchange tools. If you mount a plotter pen, you can draw check plots before commencing the actual cutting.



Cutter plunger



Creasing/scoring tool

## Automatic Registration Mark Detection Function

With the registration marks printed on the top surface used as reference points, the registration mark detection function enables automatic alignment of the cutting lines with the package design, as well as alignment of the cutting and scoring positions on the top and reverse sides. The FC4210-60 can also read registration marks generated by Adobe® Illustrator®. It's so easy to create an eye-catching prototype package—print out your design on your favorite printer, stick it onto a sheet of F/G grade microflute board or paperboard, and then use the FC4210-60 to score fold lines and cut out the design.



## Product Positioning

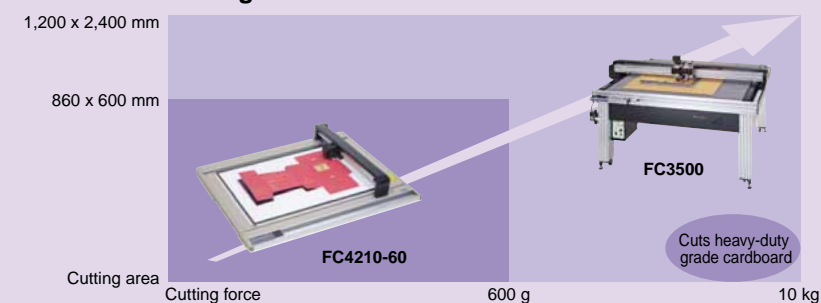

## Specifications

	<b>FC4210-60</b>
Configuration	Flatbed
Drive	Digital servo system
Effective cutting area	860 x 600 mm
Maximum loadable substrate width	666 mm
Substrate hold-down surface	Adhesive mat or adhesive sheet
Maximum cutting speed	65 cm/second
Settable cutting speeds	1 to 10, 15, 20, 25, 30, 35, 40, 45, 50, 55, 60, 65 cm/second
Cutting force	0.098 to 5.88 N (10 to 600 gf)
Mechanical resolution	0.005 mm
Programmable resolution	GP-GL: 0.1, 0.05, 0.025, 0.01 mm (menu-selectable); HP-GL™*1: 0.025 mm (fixed)
Repeatability	Within 0.1 mm*2
Distance accuracy	Within ±0.2% of the distance moved or ±0.1 mm, whichever is greater*2
Perpendicularity	Within 0.4 mm/610 mm
Registration mark reading accuracy	Within 0.2 mm*3
Sensor front/reverse position alignment accuracy	Within 0.2 mm*2
Number of cutters/tools/pens	Two
Cutter blade, tool, and pen types	Cutter blade: supersteel Creasing/scoring tool Pens: Water-based ballpoint, oil-based ballpoint
Substrate types	Paperboard up to 0.5 mm thick Microflute board (F/G grades) Clear sheets for plastic boxes Marking film (self-adhesive, fluorescent, and reflective vinyl) Stiff paper/card (for stencils, etc.) up to 0.5 mm thick*4
Interfaces	RS-232C serial and Centronics parallel (auto interface recognition)
Buffer capacity	2 MB
Command sets	GP-GL and HP-GL™ emulation (control panel-selectable)
LCD display	20 characters x 2 rows
Power requirements	100 to 120 VAC ±10%, 50/60 Hz; 220 to 240 VAC ±10%, 50/60 Hz
Power consumption	Within 120 VA
Operating environment	+10 to +35°C, 35 to 75% RH (non-condensing)
External dimensions (mm), approx.	1172 (W) x 960 (D) x 200 (H)
Weight (approx.)	27 kg

\*1 HP-GL is a trademark of Hewlett-Packard Company. \*2 When using Graphtec-specified media and conditions.

\*3 When plotting the built-in test pattern using a water-based ballpoint pen on plain paper.

\*4 Use the CB15U or CB15U-K30 blade.

## Standard Accessories

Power cable	1
Cutter plunger set	1
Water-based ballpoint pen	1
Creasing/scoring tool	1
Adhesive mat	1
Adhesive sheet	1
User's manual (FC4210-UM-151)	1
Windows plotter driver (OPS628)*5	1

\*5 For Windows 95/98/Me/NT4.0.

Please check with your Graphtec vendor if you want to use Win 2000.

## Option

Item	Model number
Floor stand	ST0032

## External Dimensions

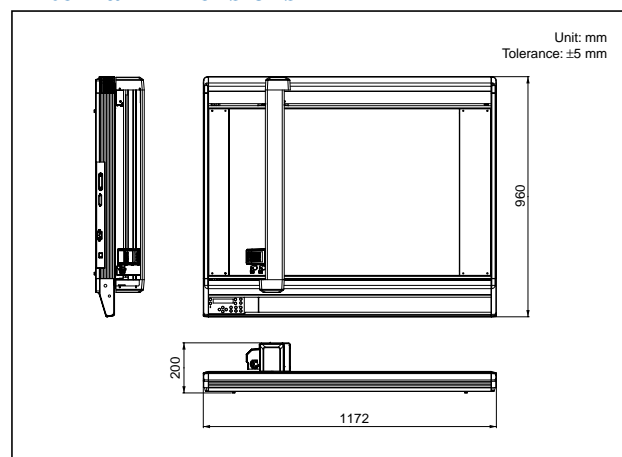

Specifications are subject to change without notice.

## GRAPHTEC CORPORATION

503-10 Shinano-cho, Totsuka-ku,  
Yokohama 244-8503, Japan  
Tel : +81(045)825-6250  
Fax : +81(045)825-6396  
Email : info@graphteccorp.com  
Web : www.graphteccorp.com



Fujisawa Plant